



NSAI

NSAI, 1 Swift Square, Northwood, Dublin 9, Ireland, D09 A0E4

Certificate of conformity of the factory production control, 0050 - CPR - 0176

In compliance with Regulation (EU) No 305/2011 of the European Parliament and of the Council of 9 March 2011 (the Construction Products Regulation or CPR), this certificate applies to the construction product(s):

Specification for masonry units – Part 3: Aggregate concrete masonry units (dense and lightweight aggregates)

Placed on the market under the name of:

**Roadstone Ltd
Huntstown, Finglas, Dublin 11**

and produced in the manufacturing plant:

**Roadstone Ltd
Huntstown, Finglas, Dublin 11**

This certificate attests that all provisions concerning the assessment and verification of constancy of performance described in Annex ZA of the standard:

I.S. EN 771-3:2011+A1:2015

under system 2+ are applied and that

the factory production control is assessed to be in conformity with the applicable requirements

This certificate was first issued on 6 December 2013 and remains valid as long as neither the harmonised standard, the construction product, the AVCP methods nor the manufacturing conditions in the plant are modified significantly, unless suspended or withdrawn by the notified factory production control certification body.

File Number: 1.116.018
Approval Date: 6 December 2013
Last Amended Date: 19 September 2024
Expiry Date: 31 October 2025

Signed:

Mr. Kevin D. Mullaney
Director of Certification, NSAI



All valid NSAI certifications are listed on NSAI's website – www.n sai.ie. The continued validity of this certificate may be verified under "Certified Company Search"



DECLARATION OF PERFORMANCE

Category 1 Aggregate Concrete Masonry Unit – Forticrete 400 Range

1. Unique identification code of the product type:

Code	Description	Strength (N/mm ²)	Length (mm)	Width (mm)	Height (mm)
K1	400 Range – Smooth Masonry – 90mm Solid	13	390	90	190
K4	400 Range – Smooth Masonry – 90mm S.P. Hollow	13	390	90	190
K12	400 Range – Smooth Masonry – 90mm Half Length Hollow	13	190	90	190
K14	400 Range – Smooth Masonry – 90mm Lintel	13	190	90	190
K15	400 Range – Smooth Masonry – 90mm Half Length Quoin	13	190	90/190 ^a	190
K16	400 Range – Smooth Masonry – 90mm Quoin	13	390	90/190 ^a	190
K17	400 Range – Smooth Masonry – 90mm Cavity Closer	13	390	90/190 ^a	190
K18	400 Range – Smooth Masonry – 90mm Half Length Cavity Closer	13	190	90/190 ^a	190
K20	400 Range – Smooth Masonry – 90mm Half Length Cill	13	190	90	190
K21	400 Range – Smooth Masonry – 90mm Cill	13	390	90	190
K23	400 Range – Smooth Masonry – 90mm 135° Quoin Squint	13	252/290E ^b	90	190
	135° extension at one end		54/90E ^b		

^aL-shaped 90° protrusion at one end; ^bExternal; Refer to drawings below

2. Type, batch or serial number or any other element allowing identification of the construction product as required under Article 11(4) of the CPR:

Production details can be traced via dispatch docket.

3. Intended use or uses of the construction product, in accordance with the applicable harmonized technical specification, as foreseen by the manufacturer:

I.S. EN 771-3 2011 Aggregate Concrete Masonry Units (Dense and Lightweight) intended for use as common, facing or exposed masonry in load bearing or non-load bearing building and civil engineering applications in accordance with Irish building Regulations, TGD in particular parts A,B,C,D,E & L, Eurocode 6 and SR 325.

4. Name, registered trade name or registered trade mark and contact address of the manufacturer as required under Article 11(5):

Roadstone Ltd.
Fortunestown
Dublin 24

5. Not Applicable

6. System or systems of assessment and verification of constancy of performance of the construction product as set out in CPR, Annex V:

System 2+

7. Notified certification body:

NSAI (identification No. 050) performed the initial inspection of the manufacturing plant and of factory production control and the continuous surveillance, assessment and evaluation of factory production control, and issued the certificate of constancy of conformity of the factory production control.

Location	FPC Cert No.
Huntstown	0050-CPR-176

8. Declared Performance

Characteristic	Declared Performance	Technical Specification
Dimensional Tolerance	D1 (+3mm, -3mm)	I.S. EN 772-16
Configuration	Category 1 to EN 1996-1-1 Group 1 See diagram(s) below	EN 1996-1-1
Gross Density (Direct Airborne Sound Insulation)	>1900kg/m ³	I.S. EN 772-13
Net Density (Direct Airborne Sound Insulation)	>1900kg/m ³	I.S. EN 772-13
Compressive Strength (Mean)	As shown in Table above, in vertical orientation	I.S. EN 772-1 (7.3.5)
Thermal Conductivity	1.01 - 1.19 W/mK (λ10,dry)	I.S. EN 1745 Annex A
Durability against freeze/thaw	F2 – Suitable for use in severe exposure	Tested in accordance with DD/CEN/TS 772:22 2006 Refer to TGD C, D & SR 325
Water Absorption	NPD	N/A
Moisture Movement	< 0.6 mm/m	I.S. EN 772-14
Water Vapour Permeability	5/15μ	I.S. EN 1745 Annex A
Reaction To Fire	Class A1	Based on Commission Decision 200/605 EC amending 96/603 EC (Refer to I.S. EN 1996-1-2 National Annex Table NA. 3.1/3.2 & 3.3 for fire ratings of wall constructed with Class A1 Units)
Shear Bond Strength	0,15N/mm ² (Tabulated)	I.S. EN 998-2
Dangerous Substances	NPD	N/A

Normal Configuration (Vertical)

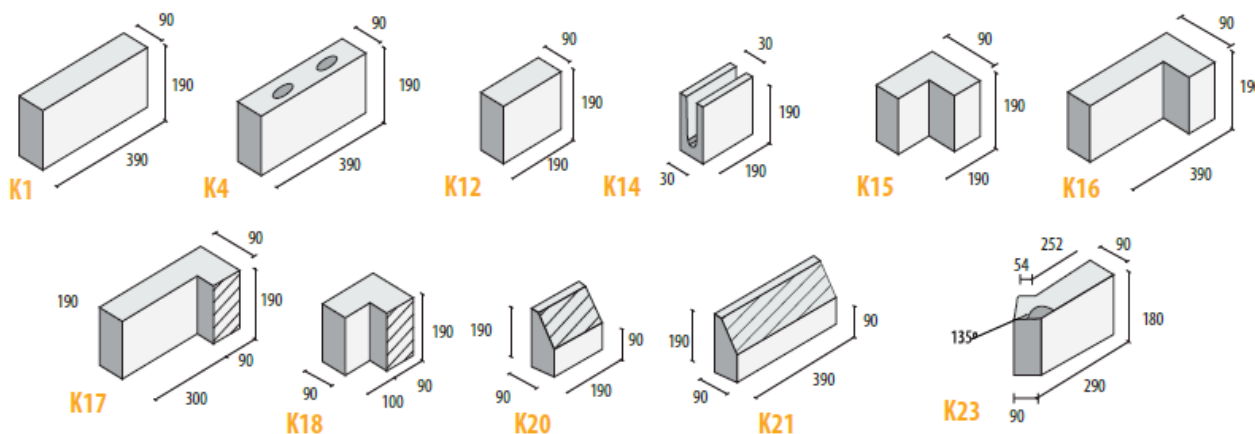

9. The performance of the product identified in points 1 and 2 is in conformity with the declared performance in point 8. This declaration of performance is issued under the sole responsibility of Roadstone Ltd.

Signed for and on behalf of the manufacturer by:

Alan Lowe, Senior Technical Manager, Roadstone Ltd.
(Name and Function)

Belgard, Feb 2020
(Place and Date of Issue)

Alan Lowe

(Signature)



13

DECLARATION OF PERFORMANCE

Category 1 Aggregate Concrete Masonry Unit – Forticrete 400 Range

1. Unique identification code of the product type:

Code	Description	Strength (N/mm ²)	Length (mm)	Width (mm)	Height (mm)
P1	400 Range – Smooth Masonry – 140mm Solid	13	390	140	190
P4	400 Range – Smooth Masonry – 140mm S.P. Hollow	13	390	140	190
P12	400 Range – Smooth Masonry – 140mm Half Length Hollow	13	190	140	190
P14	400 Range – Smooth Masonry – 140mm Lintel	13	190	140	190
P20	400 Range – Smooth Masonry – 140mm Half Length Cill	13	190	140	190
P21	400 Range – Smooth Masonry – 140mm Cill	13	390	140	190
P22	400 Range – Smooth Masonry – 140mm Bond Beam	13	390	140	190

Refer to drawings below

2. Type, batch or serial number or any other element allowing identification of the construction product as required under Article 11(4) of the CPR:

Production details can be traced via dispatch docket.

3. Intended use or uses of the construction product, in accordance with the applicable harmonized technical specification, as foreseen by the manufacturer:

I.S. EN 771-3 2011 Aggregate Concrete Masonry Units (Dense and Lightweight) intended for use as common, facing or exposed masonry in load bearing or non-load bearing building and civil engineering applications in accordance with Irish building Regulations, TGD in particular parts A,B,C,D,E & L, Eurocode 6 and SR 325.

4. Name, registered trade name or registered trade mark and contact address of the manufacturer as required under Article 11(5):

Roadstone Ltd.
 Fortunestown
 Dublin 24

5. Not Applicable

6. System or systems of assessment and verification of constancy of performance of the construction product as set out in CPR, Annex V:

System 2+

7. Notified certification body:

NSAI (identification No. 050) performed the initial inspection of the manufacturing plant and of factory production control and the continuous surveillance, assessment and evaluation of factory production control, and issued the certificate of constancy of conformity of the factory production control.

Location	FPC Cert No.
Huntstown	0050-CPR-176

8. Declared Performance

Characteristic	Declared Performance	Technical Specification
Dimensional Tolerance	D1 (+3mm, -3mm)	I.S. EN 772-16
Configuration	Category 1 to EN 1996-1-1 Group 1 See diagram(s) below	EN 1996-1-1
Gross Density (Direct Airborne Sound Insulation)	>1900kg/m ³	I.S. EN 772-13
Net Density (Direct Airborne Sound Insulation)	>1900kg/m ³	I.S. EN 772-13
Compressive Strength (Mean)	As shown in Table above, in vertical orientation	I.S. EN 772-1 (7.3.5)
Thermal Conductivity	1.01 - 1.19 W/mK ($\lambda_{10,dry}$)	I.S. EN 1745 Annex A
Durability against freeze/thaw	F2 – Suitable for use in severe exposure	Tested in accordance with DD/CEN/TS 772:22 2006 Refer to TGD C, D & SR 325
Water Absorption	NPD	N/A
Moisture Movement	< 0.6 mm/m	I.S. EN 772-14
Water Vapour Permeability	5/15 μ	I.S. EN 1745 Annex A
Reaction To Fire	Class A1	Based on Commission Decision 200/605 EC amending 96/603 EC (Refer to I.S. EN 1996-1-2 National Annex Table NA. 3.1/3.2 & 3.3 for fire ratings of wall constructed with Class A1 Units)
Shear Bond Strength	0,15N/mm ² (Tabulated)	I.S. EN 998-2
Dangerous Substances	NPD	N/A

Normal Configuration (Vertical)

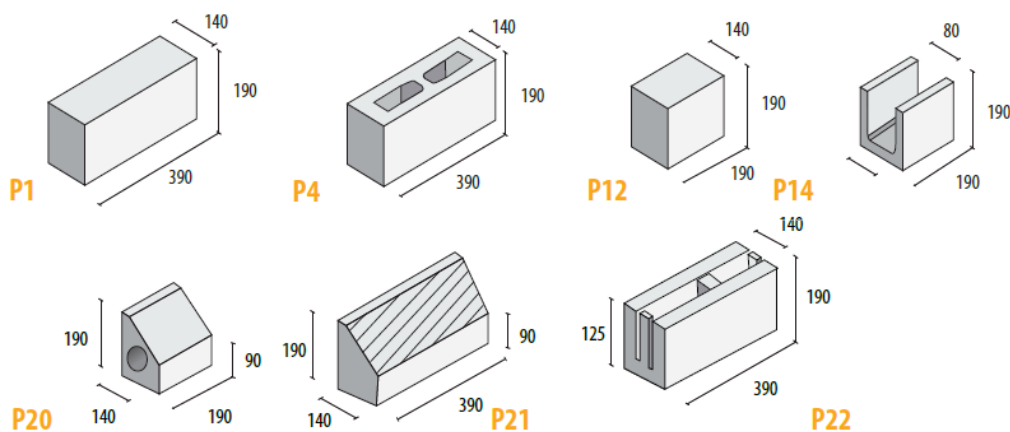

9. The performance of the product identified in points 1 and 2 is in conformity with the declared performance in point 8. This declaration of performance is issued under the sole responsibility of Roadstone Ltd.

Signed for and on behalf of the manufacturer by:

Alan Lowe, Senior Technical Manager, Roadstone Ltd.
(Name and Function)

Belgard, 28/02/2020
(Place and Date of Issue)

(Signature)

DECLARATION OF PERFORMANCE

Category 1 Aggregate Concrete Masonry Unit – Forticrete 400 Range

1. Unique identification code of the product type:

Code	Description	Strength (N/mm ²)	Length (mm)	Width (mm)	Height (mm)
R1	400 Range – Smooth Masonry – 190mm Solid	13	390	190	190
R3	400 Range – Smooth Masonry – 190mm Hollow	13	390	190	190
R4	400 Range – Smooth Masonry – 190mm S.P. Hollow	13	390	190	190
R10	400 Range – Smooth Masonry – 190mm Half Length Hollow	13	190	190	190
R12	400 Range – Smooth Masonry – 190mm Half Length (S.P.) Hollow	13	190	190	190
R14	400 Range – Smooth Masonry – 190mm Lintel	13	190	190	190
R20	400 Range – Smooth Masonry – 190mm Half Length Cill	13	190	190	190
R21	400 Range – Smooth Masonry – 190mm Cill	13	390	190	190
R22	400 Range – Smooth Masonry – 190mm Bond Beam	13	390	190	190
Refer to drawings below					

2. Type, batch or serial number or any other element allowing identification of the construction product as required under Article 11(4) of the CPR:

Production details can be traced via dispatch docket.

3. Intended use or uses of the construction product, in accordance with the applicable harmonized technical specification, as foreseen by the manufacturer:

I.S. EN 771-3 2011 Aggregate Concrete Masonry Units (Dense and Lightweight) intended for use as common, facing or exposed masonry in load bearing or non-load bearing building and civil engineering applications in accordance with Irish building Regulations, TGD in particular parts A,B,C,D,E & L, Eurocode 6 and SR 325.

4.

5. Name, registered trade name or registered trade mark and contact address of the manufacturer as required under Article 11(5):

Roadstone Ltd.
Fortunestown
Dublin 24

6. Not Applicable

7. System or systems of assessment and verification of constancy of performance of the construction product as set out in CPR, Annex V:

System 2+

8. Notified certification body:

NSAI (identification No. 050) performed the initial inspection of the manufacturing plant and of factory production control and the continuous surveillance, assessment and evaluation of factory production control, and issued the certificate of constancy of conformity of the factory production control.

Location	FPC Cert No.
Huntstown	0050-CPR-176

8. Declared Performance

Characteristic	Declared Performance	Technical Specification
Dimensional Tolerance	D1 (+3mm, -3mm)	I.S. EN 772-16
Configuration	Category 1 to EN 1996-1-1 Group 1 See diagram(s) below	EN 1996-1-1
Gross Density (Direct Airborne Sound Insulation)	>1900kg/m ³	I.S. EN 772-13
Net Density (Direct Airborne Sound Insulation)	>1900kg/m ³	I.S. EN 772-13
Compressive Strength (Mean)	As shown in Table above, in vertical orientation	I.S. EN 772-1 (7.3.5)
Thermal Conductivity	1.01 - 1.19 W/mK (λ10,dry)	I.S. EN 1745 Annex A
Durability against freeze/thaw	F2 – Suitable for use in severe exposure	Tested in accordance with DD/CEN/TS 772:22 2006 Refer to TGD C, D & SR 325
Water Absorption	NPD	N/A
Moisture Movement	< 0.6 mm/m	I.S. EN 772-14
Water Vapour Permeability	5/15μ	I.S. EN 1745 Annex A
Reaction To Fire	Class A1	Based on Commission Decision 200/605 EC amending 96/603 EC (Refer to I.S. EN 1996-1-2 National Annex Table NA. 3.1/3.2 & 3.3 for fire ratings of wall constructed with Class A1 Units)
Shear Bond Strength	0,15N/mm ² (Tabulated)	I.S. EN 998-2
Dangerous Substances	NPD	N/A

Normal Configuration (Vertical)

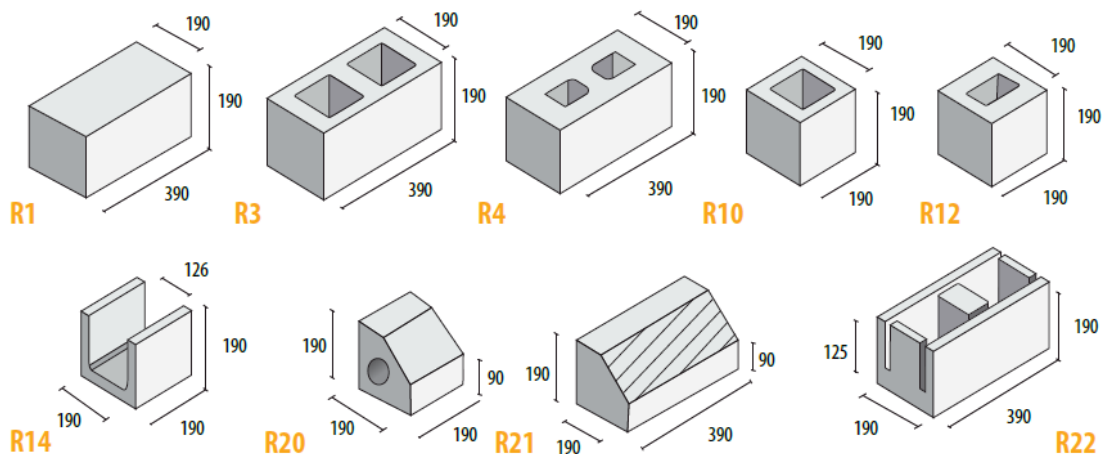

9. The performance of the product identified in points 1 and 2 is in conformity with the declared performance in point 8. This declaration of performance is issued under the sole responsibility of Roadstone Ltd.

Signed for and on behalf of the manufacturer by:

Alan Lowe, Senior Technical Manager, Roadstone Ltd.
(Name and Function)

Belgard, 28 Feb 2020
(Place and Date of Issue)

(Signature)

DECLARATION OF PERFORMANCE

Category 1 Aggregate Concrete Masonry Unit – Forticrete 400 Range

1. Unique identification code of the product type:

Code	Description	Strength (N/mm ²)	Length (mm)	Width (mm)	Height (mm)
S3	400 Range – Textured Masonry – Split	13	390	95	90
S4	400 Range – Textured Masonry – Split	13	190	95	90
S7	400 Range – Textured Masonry – Split	13	390	95	190
S8	400 Range – Textured Masonry – Split	13	190	95	190
S9	400 Range – Textured Masonry – Split	13	390	195	190
S10	400 Range – Textured Masonry – Split	13	190	195	190

Refer to drawings below

2. Type, batch or serial number or any other element allowing identification of the construction product as required under Article 11(4) of the CPR:

Production details can be traced via dispatch docket.

3. Intended use or uses of the construction product, in accordance with the applicable harmonized technical specification, as foreseen by the manufacturer:

I.S. EN 771-3 2011 Aggregate Concrete Masonry Units (Dense and Lightweight) intended for use as common, facing or exposed masonry in load bearing or non-load bearing building and civil engineering applications in accordance with Irish building Regulations, TGD in particular parts A,B,C,D,E & L, Eurocode 6 and SR 325.

4. Name, registered trade name or registered trade mark and contact address of the manufacturer as required under Article 11(5):

Roadstone Ltd.
Fortunestown
Dublin 24

5. Not Applicable

6. System or systems of assessment and verification of constancy of performance of the construction product as set out in CPR, Annex V:

System 2+

7. Notified certification body:

NSAI (identification No. 050) performed the initial inspection of the manufacturing plant and of factory production control and the continuous surveillance, assessment and evaluation of factory production control, and issued the certificate of constancy of conformity of the factory production control.

Location	FPC Cert No.
Huntstown	0050-CPR-176

8. Declared Performance

Characteristic	Declared Performance	Harmonised Technical Specification
Dimensional Tolerance	D1 (+3mm, -3mm)	I.S. EN 772-16
Configuration	Category 1 to EN 1996-1-1 Group 1 See diagram(s) below	EN 1996-1-1
Gross Density (Direct Airborne Sound Insulation)	>1900kg/m ³	I.S. EN 772-13
Net Density (Direct Airborne Sound Insulation)	>1900kg/m ³	I.S. EN 772-13
Compressive Strength (Mean)	As shown in Table above, in vertical orientation	I.S. EN 772-1 (7.3.5)
Thermal Conductivity	1.01 - 1.19 W/mK (λ10,dry)	I.S. EN 1745 Annex A
Durability against freeze/thaw	F2 – Suitable for use in severe exposure	Tested in accordance with DD/CEN/TS 772:22 2006 Refer to TGD C, D & SR 325
Water Absorption	NPD	N/A
Moisture Movement	< 0.6 mm/m	I.S. EN 772-14
Water Vapour Permeability	5/15μ	I.S. EN 1745 Annex A
Reaction To Fire	Class A1	Based on Commission Decision 200/605 EC amending 96/603 EC (Refer to I.S. EN 1996-1-2 National Annex Table NA. 3.1/3.2 & 3.3 for fire ratings of wall constructed with Class A1 Units)
Shear Bond Strength	0,15N/mm ² (Tabulated)	I.S. EN 998-2
Dangerous Substances	NPD	N/A

Normal Configuration (Vertical)

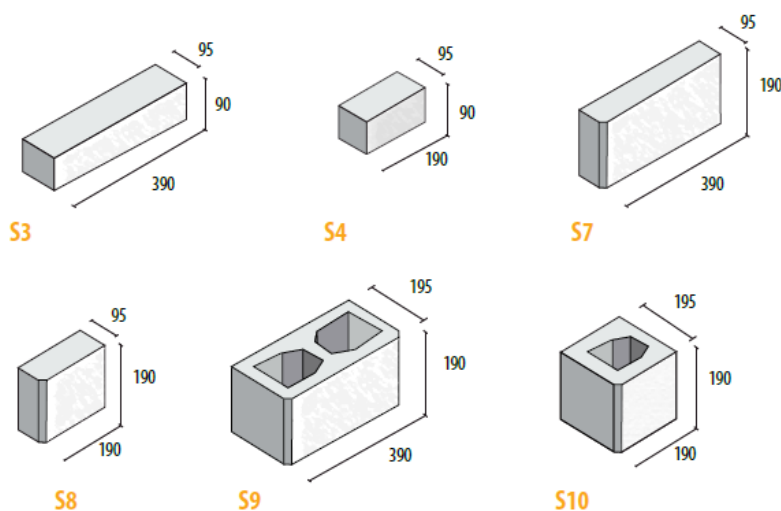

9. The performance of the product identified in points 1 and 2 is in conformity with the declared performance in point 8. This declaration of performance is issued under the sole responsibility of Roadstone Ltd.

Signed for and on behalf of the manufacturer by:

Alan Lowe, Senior Technical Manager, Roadstone Ltd.

(Name and Function)

Belgard, 28 Feb 2020

(Place and Date of Issue)

Alan Lowe

(Signature)



13

DECLARATION OF PERFORMANCE

Category 1 Aggregate Concrete Masonry Unit – Forticrete 400 Range

1. Unique identification code of the product type:

Code	Description	Strength (N/mm ²)	Length (mm)	Width (mm)	Height (mm)
G1	400 Range – Textured Masonry – Grooved	13	390	95	190
G2	400 Range – Textured Masonry – Grooved	13	390	190	190
SF40	400 Range – Textured Masonry – Grooved	13	190	95	190
SF41	400 Range – Textured Masonry – Grooved	13	390	95	190
SF42	400 Range – Textured Masonry – Grooved	13	390	195	190
SF43	400 Range – Textured Masonry – Grooved	13	390	195	190
SF44	400 Range – Textured Masonry – Grooved	13	190	195	190

Refer to drawings below

2. Type, batch or serial number or any other element allowing identification of the construction product as required under Article 11(4) of the CPR:

Production details can be traced via dispatch docket.

3. Intended use or uses of the construction product, in accordance with the applicable harmonized technical specification, as foreseen by the manufacturer:

I.S. EN 771-3 2011 Aggregate Concrete Masonry Units (Dense and Lightweight) intended for use as common, facing or exposed masonry in load bearing or non-load bearing building and civil engineering applications in accordance with Irish building Regulations, TGD in particular parts A,B,C,D,E & L, Eurocode 6 and SR 325.

4. Name, registered trade name or registered trade mark and contact address of the manufacturer as required under Article 11(5):

Roadstone Ltd.
 Fortunestown
 Dublin 24

5. Not Applicable

6. System or systems of assessment and verification of constancy of performance of the construction product as set out in CPR, Annex V:

System 2+

7. Notified certification body:

NSAI (identification No. 050) performed the initial inspection of the manufacturing plant and of factory production control and the continuous surveillance, assessment and evaluation of factory production control, and issued the certificate of constancy of conformity of the factory production control.

Location	FPC Cert No.
Huntstown	0050-CPR-176

8. Declared Performance

Characteristic	Declared Performance	Technical Specification
Dimensional Tolerance	D1 (+3mm, -3mm)	I.S. EN 772-16
Configuration	Category 1 to EN 1996-1-1 Group 1 See diagram(s) below	EN 1996-1-1
Gross Density (Direct Airborne Sound Insulation)	>1900kg/m ³	I.S. EN 772-13
Net Density (Direct Airborne Sound Insulation)	>1900kg/m ³	I.S. EN 772-13
Compressive Strength (Mean)	As shown in Table above, in vertical orientation	I.S. EN 772-1 (7.3.5)
Thermal Conductivity	1.01 - 1.19 W/mK (λ10,dry)	I.S. EN 1745 Annex A
Durability against freeze/thaw	F2 – Suitable for use in severe exposure	Tested in accordance with DD/CEN/TS 772:22 2006 Refer to TGD C, D & SR 325
Water Absorption	NPD	N/A
Moisture Movement	< 0.6 mm/m	I.S. EN 772-14
Water Vapour Permeability	5/15μ	I.S. EN 1745 Annex A
Reaction To Fire	Class A1	Based on Commission Decision 200/605 EC amending 96/603 EC (Refer to I.S. EN 1996-1-2 National Annex Table NA. 3.1/3.2 & 3.3 for fire ratings of wall constructed with Class A1 Units)
Shear Bond Strength	0,15N/mm ² (Tabulated)	I.S. EN 998-2
Dangerous Substances	NPD	N/A

Normal Configuration (Vertical)

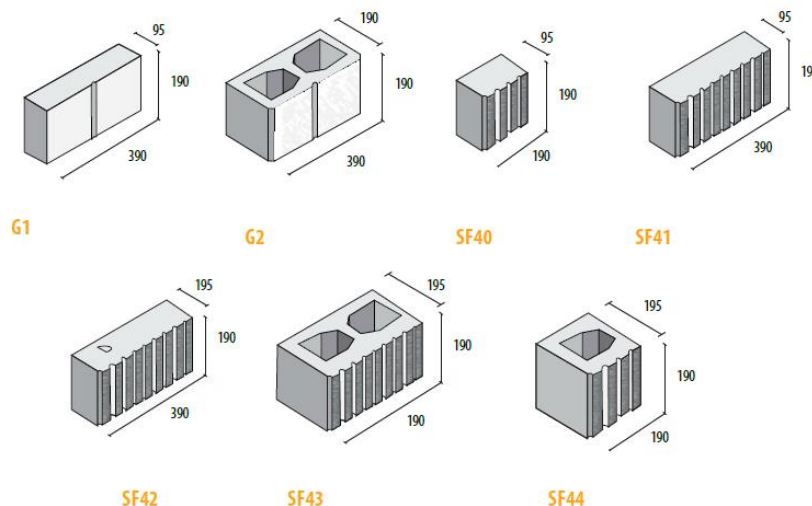

9. The performance of the product identified in points 1 and 2 is in conformity with the declared performance in point 8. This declaration of performance is issued under the sole responsibility of Roadstone Ltd.

Signed for and on behalf of the manufacturer by:

Alan Lowe, Senior Technical Manager, Roadstone Ltd.

(Name and Function)

Belgard, 28 Feb 2020

(Place and Date of Issue)

Alan Lowe

(Signature)

DECLARATION OF PERFORMANCE

Category 1 Aggregate Concrete Masonry Unit – Forticrete 450 Range

1. Unique identification code of the product type:

Code	Description	Strength (N/mm ²)	Length (mm)	Width (mm)	Height (mm)
D1	450 Range – Smooth Masonry – 100mm Solid	13	440	100	215
D4	450 Range – Smooth Masonry – 100mm S.P. Hollow	13	440	100	215
D12	450 Range – Smooth Masonry – 100mm Half Length (S.P.) Hollow	13	215	100	215
D14	450 Range – Smooth Masonry – 100mm Lintel	13	215	100	215
D15	450 Range – Smooth Masonry – 100mm Half Length Quoin	13	215	100/215 ^a	215
D16	450 Range – Smooth Masonry – 100mm Quoin	13	440	100/215 ^a	215
D17	450 Range – Smooth Masonry – 100mm Cavity Closer	13	440	100/215 ^a	215
D18	450 Range – Smooth Masonry – 100mm Half Length Cavity Closer	13	215	100/215 ^a	215
D20	450 Range – Smooth Masonry – 100mm Cill	13	440	100	215
D21	450 Range – Smooth Masonry – 100mm Half Length Cill	13	215	100	215

^aL-shaped 90° protrusion at one end; Refer to drawings below

2. Type, batch or serial number or any other element allowing identification of the construction product as required under Article 11(4) of the CPR:

Production details can be traced via dispatch docket.

3. Intended use or uses of the construction product, in accordance with the applicable harmonized technical specification, as foreseen by the manufacturer:

I.S. EN 771-3 2011 Aggregate Concrete Masonry Units (Dense and Lightweight) intended for use as common, facing or exposed masonry in load bearing or non-load bearing building and civil engineering applications in accordance with Irish building Regulations, TGD in particular parts A,B,C,D,E & L, Eurocode 6 and SR 325.

4. Name, registered trade name or registered trade mark and contact address of the manufacturer as required under Article 11(5):

Roadstone Ltd.
 Fortunestown
 Dublin 24

5. Not Applicable

6. System or systems of assessment and verification of constancy of performance of the construction product as set out in CPR, Annex V:

System 2+

7. Notified certification body:

NSAI (identification No. 050) performed the initial inspection of the manufacturing plant and of factory production control and the continuous surveillance, assessment and evaluation of factory production control, and issued the certificate of constancy of conformity of the factory production control.

Location	FPC Cert No.
Huntstown	0050-CPR-176

8. Declared Performance

Characteristic	Declared Performance	Technical Specification
Dimensional Tolerance	D1 (+3mm, -3mm)	I.S. EN 772-16
Configuration	Category 1 to EN 1996-1-1 Group 1 See diagram(s) below	EN 1996-1-1
Gross Density (Direct Airborne Sound Insulation)	>1900kg/m ³	I.S. EN 772-13
Net Density (Direct Airborne Sound Insulation)	>1900kg/m ³	I.S. EN 772-13
Compressive Strength (Mean)	As shown in Table above, in vertical orientation	I.S. EN 772-1 (7.3.5)
Thermal Conductivity	1.01 - 1.19 W/mK (λ10,dry)	I.S. EN 1745 Annex A
Durability against freeze/thaw	F2 – Suitable for use in severe exposure	Tested in accordance with DD/CEN/TS 772:22 2006 Refer to TGD C, D & SR 325
Water Absorption	NPD	N/A
Moisture Movement	< 0.6 mm/m	I.S. EN 772-14
Water Vapour Permeability	5/15μ	I.S. EN 1745 Annex A
Reaction To Fire	Class A1	Based on Commission Decision 200/605 EC amending 96/603 EC (Refer to I.S. EN 1996-1-2 National Annex Table NA. 3.1/3.2 & 3.3 for fire ratings of wall constructed with Class A1 Units)
Shear Bond Strength	0,15N/mm ² (Tabulated)	I.S. EN 998-2
Dangerous Substances	NPD	N/A

Normal Configuration (Vertical)

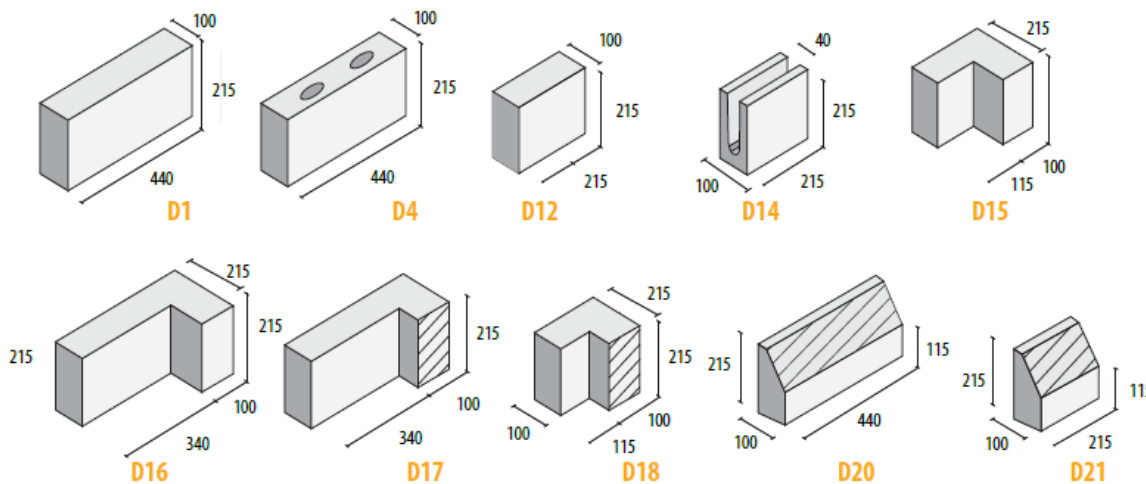

9. The performance of the product identified in points 1 and 2 is in conformity with the declared performance in point 8. This declaration of performance is issued under the sole responsibility of Roadstone Ltd.

Signed for and on behalf of the manufacturer by:

Alan Lowe, Senior Technical Manager, Roadstone Ltd.
(Name and Function)

Belgard, 28 Feb 2020
(Place and Date of Issue)

Alan Lowe

(Signature)



13

DECLARATION OF PERFORMANCE

Category 1 Aggregate Concrete Masonry Unit – Forticrete 450 Range

1. Unique identification code of the product type:

Code	Description	Strength (N/mm ²)	Length (mm)	Width (mm)	Height (mm)
H1	450 Range – Smooth Masonry – 140mm Solid	13	440	140	215
H3	450 Range – Smooth Masonry – 140mm Hollow	13	440	140	215
H20	450 Range – Smooth Masonry – 100mm Half Length Cill	13	215	140	215
H21	450 Range – Smooth Masonry – 140mm Cill	13	440	140	215
Refer to drawings below					

2. Type, batch or serial number or any other element allowing identification of the construction product as required under Article 11(4) of the CPR:

Production details can be traced via dispatch docket.

3. Intended use or uses of the construction product, in accordance with the applicable harmonized technical specification, as foreseen by the manufacturer:

I.S. EN 771-3 2011 Aggregate Concrete Masonry Units (Dense and Lightweight) intended for use as common, facing or exposed masonry in load bearing or non-load bearing building and civil engineering applications in accordance with Irish building Regulations, TGD in particular parts A,B,C,D,E & L, Eurocode 6 and SR 325.

4. Name, registered trade name or registered trade mark and contact address of the manufacturer as required under Article 11(5):

Roadstone Ltd.
Fortunestown
Dublin 24

5. Not Applicable

6. System or systems of assessment and verification of constancy of performance of the construction product as set out in CPR, Annex V:

System 2+

7. Notified certification body:

NSAI (identification No. 050) performed the initial inspection of the manufacturing plant and of factory production control and the continuous surveillance, assessment and evaluation of factory production control, and issued the certificate of constancy of conformity of the factory production control.

Location	FPC Cert No.
Huntstown	0050-CPR-176

8. Declared Performance

Characteristic	Declared Performance	Technical Specification
Dimensional Tolerance	D1 (+3mm, -3mm)	I.S. EN 772-16
Configuration	Category 1 to EN 1996-1-1 Group 1 See diagram(s) below	EN 1996-1-1
Gross Density (Direct Airborne Sound Insulation)	>1900kg/m ³	I.S. EN 772-13
Net Density (Direct Airborne Sound Insulation)	>1900kg/m ³	I.S. EN 772-13
Compressive Strength (Mean)	As shown in Table above, in vertical orientation	I.S. EN 772-1 (7.3.5)
Thermal Conductivity	1.01 - 1.19 W/mK (λ10,dry)	I.S. EN 1745 Annex A
Durability against freeze/thaw	F2 – Suitable for use in severe exposure	Tested in accordance with DD/CEN/TS 772:22 2006 Refer to TGD C, D & SR 325
Water Absorption	NPD	N/A
Moisture Movement	< 0.6 mm/m	I.S. EN 772-14
Water Vapour Permeability	5/15μ	I.S. EN 1745 Annex A
Reaction To Fire	Class A1	Based on Commission Decision 200/605 EC amending 96/603 EC (Refer to I.S. EN 1996-1-2 National Annex Table NA. 3.1/3.2 & 3.3 for fire ratings of wall constructed with Class A1 Units)
Shear Bond Strength	0,15N/mm ² (Tabulated)	I.S. EN 998-2
Dangerous Substances	NPD	N/A

Normal Configuration (Vertical)

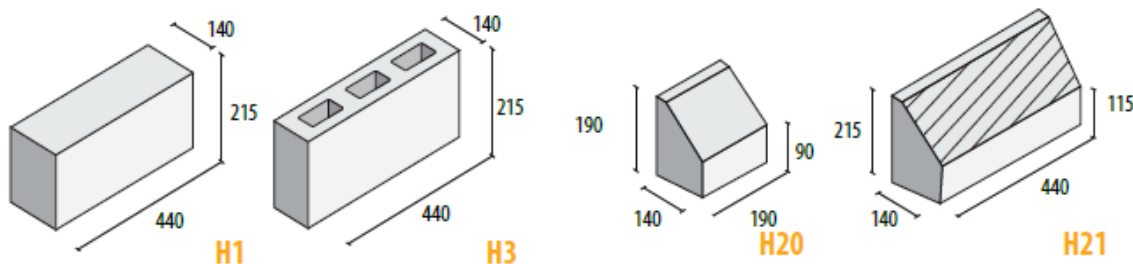

9. The performance of the product identified in points 1 and 2 is in conformity with the declared performance in point 8. This declaration of performance is issued under the sole responsibility of Roadstone Ltd.

Signed for and on behalf of the manufacturer by:

Alan Lowe, Senior Technical Manager, Roadstone Ltd.
(Name and Function)
Belgard, 28 Feb 2020
(Place and Date of Issue)

Alan Lowe

(Signature)

DECLARATION OF PERFORMANCE

Category 1 Aggregate Concrete Masonry Unit – Forticrete 450 Range

1. Unique identification code of the product type:

Code	Description	Strength (N/mm ²)	Length (mm)	Width (mm)	Height (mm)
F1	450 Range – Smooth Masonry – 215mm Solid	13	440	215	215
F3	450 Range – Smooth Masonry – 215mm Hollow	13	440	215	215
F10	450 Range – Smooth Masonry – 215mm Half Length Hollow	13	215	215	215
F14	450 Range – Smooth Masonry – 215mm Lintel	13	215	215	215
F20	450 Range – Smooth Masonry – 215mm Half Cill	13	215	215	215
F21	450 Range – Smooth Masonry – 215mm Cill	13	440	215	215
F22	450 Range – Smooth Masonry – 215mm Bond Beam	13	440	215	215

Refer to drawings below

2. Type, batch or serial number or any other element allowing identification of the construction product as required under Article 11(4) of the CPR:

Production details can be traced via dispatch docket.

3. Intended use or uses of the construction product, in accordance with the applicable harmonized technical specification, as foreseen by the manufacturer:

I.S. EN 771-3 2011 Aggregate Concrete Masonry Units (Dense and Lightweight) intended for use as common, facing or exposed masonry in load bearing or non-load bearing building and civil engineering applications in accordance with Irish building Regulations, TGD in particular parts A,B,C,D,E & L, Eurocode 6 and SR 325.

4. Name, registered trade name or registered trade mark and contact address of the manufacturer as required under Article 11(5):

Roadstone Ltd.
Fortunestown
Dublin 24

5. Not Applicable

6. System or systems of assessment and verification of constancy of performance of the construction product as set out in CPR, Annex V:

System 2+

7. Notified certification body:

NSAI (identification No. 050) performed the initial inspection of the manufacturing plant and of factory production control and the continuous surveillance, assessment and evaluation of factory production control, and issued the certificate of constancy of conformity of the factory production control.

Location	FPC Cert No.
Huntstown	0050-CPR-176

8. Declared Performance

Characteristic	Declared Performance	Technical Specification
Dimensional Tolerance	D1 (+3mm, -3mm)	I.S. EN 772-16
Configuration	Category 1 to EN 1996-1-1 Group 1 See diagram(s) below	EN 1996-1-1
Gross Density (Direct Airborne Sound Insulation)	>1900kg/m ³	I.S. EN 772-13
Net Density (Direct Airborne Sound Insulation)	>1900kg/m ³	I.S. EN 772-13
Compressive Strength (Mean)	As shown in Table above, in vertical orientation	I.S. EN 772-1 (7.3.5)
Thermal Conductivity	1.01 - 1.19 W/mK (λ10,dry)	I.S. EN 1745 Annex A
Durability against freeze/thaw	F2 – Suitable for use in severe exposure	Tested in accordance with DD/CEN/TS 772:22 2006 Refer to TGD C, D & SR 325
Water Absorption	NPD	N/A
Moisture Movement	< 0.6 mm/m	I.S. EN 772-14
Water Vapour Permeability	5/15μ	I.S. EN 1745 Annex A
Reaction To Fire	Class A1	Based on Commission Decision 200/605 EC amending 96/603 EC (Refer to I.S. EN 1996-1-2 National Annex Table NA. 3.1/3.2 & 3.3 for fire ratings of wall constructed with Class A1 Units)
Shear Bond Strength	0,15N/mm ² (Tabulated)	I.S. EN 998-2
Dangerous Substances	NPD	N/A

Normal Configuration (Vertical)

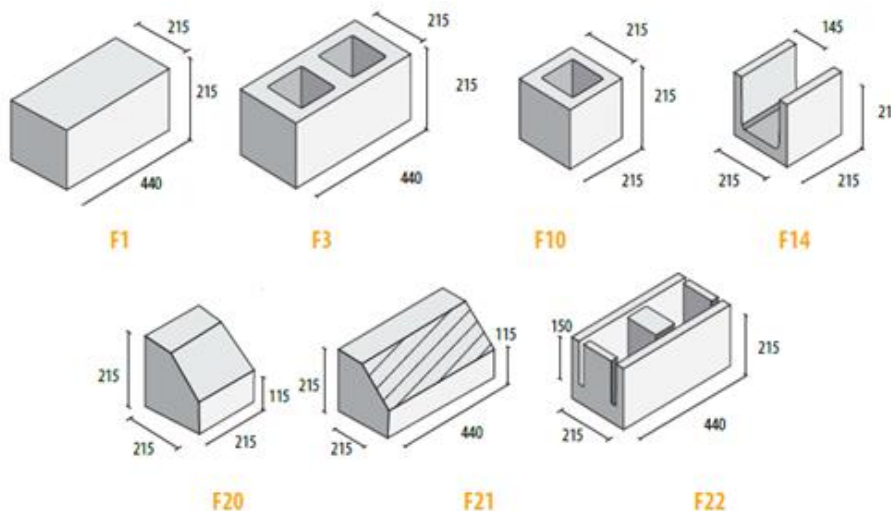

9. The performance of the product identified in points 1 and 2 is in conformity with the declared performance in point 8. This declaration of performance is issued under the sole responsibility of Roadstone Ltd.

Signed for and on behalf of the manufacturer by:

Alan Lowe, Senior Technical Manager, Roadstone Ltd.
(Name and Function)

Belgard, 28 Feb 2020
(Place and Date of Issue)

Alan Lowe

(Signature)

DECLARATION OF PERFORMANCE

Category 1 Aggregate Concrete Masonry Unit – Forticrete 450 Range

1. Unique identification code of the product type:

Code	Description	Strength (N/mm ²)	Length (mm)	Width (mm)	Height (mm)
S51	450 Range – Textured Masonry	13	440	107	65
S52	450 Range – Textured Masonry	13	215	107	65
S53	450 Range – Textured Masonry	13	440	107	100
S54	450 Range – Textured Masonry	13	215	107	100
S55	450 Range – Textured Masonry	13	440	107	140
S56	450 Range – Textured Masonry	13	215	107	215
S57	450 Range – Textured Masonry	13	440	107	215
S58	450 Range – Textured Masonry	13	215	107	215
S59	450 Range – Textured Masonry	13	440	220	215
S60	450 Range – Textured Masonry	13	215	220	215

Refer to drawings below

2. Type, batch or serial number or any other element allowing identification of the construction product as required under Article 11(4) of the CPR:

Production details can be traced via dispatch docket.

3. Intended use or uses of the construction product, in accordance with the applicable harmonized technical specification, as foreseen by the manufacturer:

I.S. EN 771-3 2011 Aggregate Concrete Masonry Units (Dense and Lightweight) intended for use as common, facing or exposed masonry in load bearing or non-load bearing building and civil engineering applications in accordance with Irish building Regulations, TGD in particular parts A,B,C,D,E & L, Eurocode 6 and SR 325.

4. Name, registered trade name or registered trade mark and contact address of the manufacturer as required under Article 11(5):

Roadstone Ltd.
Fortunestown
Dublin 24

5. Not Applicable

6. System or systems of assessment and verification of constancy of performance of the construction product as set out in CPR, Annex V:

System 2+

7. Notified certification body:

NSAI (identification No. 050) performed the initial inspection of the manufacturing plant and of factory production control and the continuous surveillance, assessment and evaluation of factory production control, and issued the certificate of constancy of conformity of the factory production control.

Location	FPC Cert No.
Huntstown	0050-CPR-176

8. Declared Performance

Characteristic	Declared Performance	Technical Specification
Dimensional Tolerance	D1 (+3mm, -3mm)	I.S. EN 772-16
Configuration	Category 1 to EN 1996-1-1 Group 1 See diagram(s) below	EN 1996-1-1
Gross Density (Direct Airborne Sound Insulation)	>1900kg/m ³	I.S. EN 772-13
Net Density (Direct Airborne Sound Insulation)	>1900kg/m ³	I.S. EN 772-13
Compressive Strength (Mean)	As shown in Table above, in vertical orientation	I.S. EN 772-1 (7.3.5)
Thermal Conductivity	1.01 - 1.19 W/mK (λ10,dry)	I.S. EN 1745 Annex A
Durability against freeze/thaw	F2 – Suitable for use in severe exposure	Tested in accordance with DD/CEN/TS 772:22 2006 Refer to TGD C, D & SR 325
Water Absorption	NPD	N/A
Moisture Movement	< 0.6 mm/m	I.S. EN 772-14
Water Vapour Permeability	5/15μ	I.S. EN 1745 Annex A
Reaction To Fire	Class A1	Based on Commission Decision 200/605 EC amending 96/603 EC (Refer to I.S. EN 1996-1-2 National Annex Table NA. 3.1/3.2 & 3.3 for fire ratings of wall constructed with Class A1 Units)
Shear Bond Strength	0,15N/mm ² (Tabulated)	I.S. EN 998-2
Dangerous Substances	NPD	N/A

Normal Configuration (Vertical)

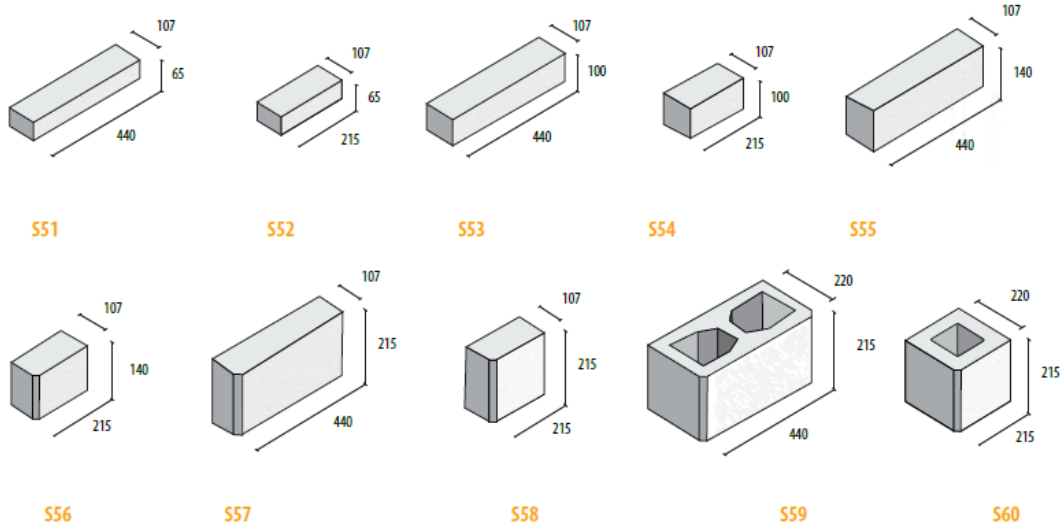

9. The performance of the product identified in points 1 and 2 is in conformity with the declared performance in point 8. This declaration of performance is issued under the sole responsibility of Roadstone Ltd.

Signed for and on behalf of the manufacturer by:

Alan Lowe, Senior Technical Manager, Roadstone Ltd.
(Name and Function)

Belgard, 28 Feb 2020
(Place and Date of Issue)

(Signature)



13

DECLARATION OF PERFORMANCE

Category 1 Aggregate Concrete Masonry Unit – Forticrete 450 Range

1. Unique identification code of the product type:

Code	Description	Strength (N/mm ²)	Length (mm)	Width (mm)	Height (mm)
SR51	450 Range – Textured Masonry – Split Ribbed	13	440	107	215
SS51	450 Range – Textured Masonry – Split Grooved	13	440	107	215
SF50	450 Range – Textured Masonry – Split Fluted	13	215	107	215
SF51	450 Range – Textured Masonry – Split Fluted	13	440	107	215
SF52	450 Range – Textured Masonry – Split Fluted	13	440	107	215
SF52	450 Range – Textured Masonry – Split Fluted	13	440	220	215
SF54	450 Range – Textured Masonry – Split Fluted	13	215	220	215

Refer to drawings below

2. Type, batch or serial number or any other element allowing identification of the construction product as required under Article 11(4) of the CPR:

Production details can be traced via dispatch docket.

3. Intended use or uses of the construction product, in accordance with the applicable harmonized technical specification, as foreseen by the manufacturer:

I.S. EN 771-3 2011 Aggregate Concrete Masonry Units (Dense and Lightweight) intended for use as common, facing or exposed masonry in load bearing or non-load bearing building and civil engineering applications in accordance with Irish building Regulations, TGD in particular parts A,B,C,D,E & L, Eurocode 6 and SR 325.

4. Name, registered trade name or registered trade mark and contact address of the manufacturer as required under Article 11(5):

Roadstone Ltd.
 Fortunestown
 Dublin 24

5. Not Applicable

6. System or systems of assessment and verification of constancy of performance of the construction product as set out in CPR, Annex V:

System 2+

7. Notified certification body:

NSAI (identification No. 050) performed the initial inspection of the manufacturing plant and of factory production control and the continuous surveillance, assessment and evaluation of factory production control, and issued the certificate of constancy of conformity of the factory production control.

Location	FPC Cert No.
Huntstown	0050-CPR-176

8. Declared Performance

Characteristic	Declared Performance	Technical Specification
Dimensional Tolerance	D1 (+3mm, -3mm)	I.S. EN 772-16
Configuration	Category 1 to EN 1996-1-1 Group 1 See diagram(s) below	EN 1996-1-1
Gross Density (Direct Airborne Sound Insulation)	>1900kg/m ³	I.S. EN 772-13
Net Density (Direct Airborne Sound Insulation)	>1900kg/m ³	I.S. EN 772-13
Compressive Strength (Mean)	As shown in Table above, in vertical orientation	I.S. EN 772-1 (7.3.5)
Thermal Conductivity	1.01 - 1.19 W/mK (λ10,dry)	I.S. EN 1745 Annex A
Durability against freeze/thaw	F2 – Suitable for use in severe exposure	Tested in accordance with DD/CEN/TS 772:22 2006 Refer to TGD C, D & SR 325
Water Absorption	NPD	N/A
Moisture Movement	< 0.6 mm/m	I.S. EN 772-14
Water Vapour Permeability	5/15μ	I.S. EN 1745 Annex A
Reaction To Fire	Class A1	Based on Commission Decision 200/605 EC amending 96/603 EC (Refer to I.S. EN 1996-1-2 National Annex Table NA. 3.1/3.2 & 3.3 for fire ratings of wall constructed with Class A1 Units)
Shear Bond Strength	0,15N/mm ² (Tabulated)	I.S. EN 998-2
Dangerous Substances	NPD	N/A

Normal Configuration (Vertical)

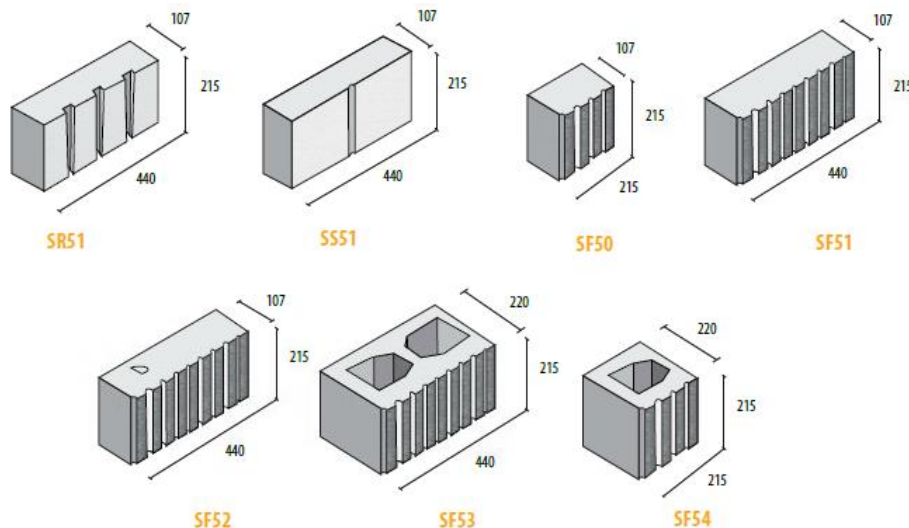

9. The performance of the product identified in points 1 and 2 is in conformity with the declared performance in point 8. This declaration of performance is issued under the sole responsibility of Roadstone Ltd.

Signed for and on behalf of the manufacturer by:

Alan Lowe, Senior Technical Manager, Roadstone Ltd.

(Name and Function)

Belgard, 28 Feb 2020

(Place and Date of Issue)

Alan Lowe

(Signature)



13

DECLARATION OF PERFORMANCE

Category 1 Aggregate Concrete Masonry Unit – Forticrete Specials

1. Unique identification code of the product type:

Code	Description	Strength (N/mm ²)	Length (mm)	Width (mm)	Height (mm)
X1	Specials – Standard Unit	13	215	215	100
X2	Specials – Standard Unit	13	215	215	100
X3	Specials – Standard Unit	13	215	215	140
H20	Specials – Standard Unit	13	215	140	215
H20	Specials – Standard Unit	13	215	215	140
F20	Specials – Standard Unit	13	215	215	215
F26D	Specials – Standard Unit	13	215	440	215

Refer to drawings below

2. Type, batch or serial number or any other element allowing identification of the construction product as required under Article 11(4) of the CPR:

Production details can be traced via dispatch docket.

3. Intended use or uses of the construction product, in accordance with the applicable harmonized technical specification, as foreseen by the manufacturer:

I.S. EN 771-3 2011 Aggregate Concrete Masonry Units (Dense and Lightweight) intended for use as common, facing or exposed masonry in load bearing or non-load bearing building and civil engineering applications in accordance with Irish building Regulations, TGD in particular parts A,B,C,D,E & L, Eurocode 6 and SR 325.

4. Name, registered trade name or registered trade mark and contact address of the manufacturer as required under Article 11(5):

Roadstone Ltd.
Fortunestown
Dublin 24

5. Not Applicable

6. System or systems of assessment and verification of constancy of performance of the construction product as set out in CPR, Annex V:

System 2+

7. Notified certification body:

NSAI (identification No. 050) performed the initial inspection of the manufacturing plant and of factory production control and the continuous surveillance, assessment and evaluation of factory production control, and issued the certificate of constancy of conformity of the factory production control.

Location	FPC Cert No.
Huntstown	0050-CPR-176

8. Declared Performance

Characteristic	Declared Performance	Technical Specification
Dimensional Tolerance	D1 (+3mm, -3mm)	I.S. EN 772-16
Configuration	Category 1 to EN 1996-1-1 Group 1 See diagram(s) below	EN 1996-1-1
Gross Density (Direct Airborne Sound Insulation)	>1900kg/m ³	I.S. EN 772-13
Net Density (Direct Airborne Sound Insulation)	>1900kg/m ³	I.S. EN 772-13
Compressive Strength (Mean)	As shown in Table above, in vertical orientation	I.S. EN 772-1 (7.3.5)
Thermal Conductivity	1.01 - 1.19 W/mK (λ10,dry)	I.S. EN 1745 Annex A
Durability against freeze/thaw	F2 – Suitable for use in severe exposure	Tested in accordance with DD/CEN/TS 772:22 2006 Refer to TGD C, D & SR 325
Water Absorption	NPD	N/A
Moisture Movement	< 0.6 mm/m	I.S. EN 772-14
Water Vapour Permeability	5/15μ	I.S. EN 1745 Annex A
Reaction To Fire	Class A1	Based on Commission Decision 200/605 EC amending 96/603 EC (Refer to I.S. EN 1996-1-2 National Annex Table NA. 3.1/3.2 & 3.3 for fire ratings of wall constructed with Class A1 Units)
Shear Bond Strength	0,15N/mm ² (Tabulated)	I.S. EN 998-2
Dangerous Substances	NPD	N/A

Normal Configuration (Vertical)

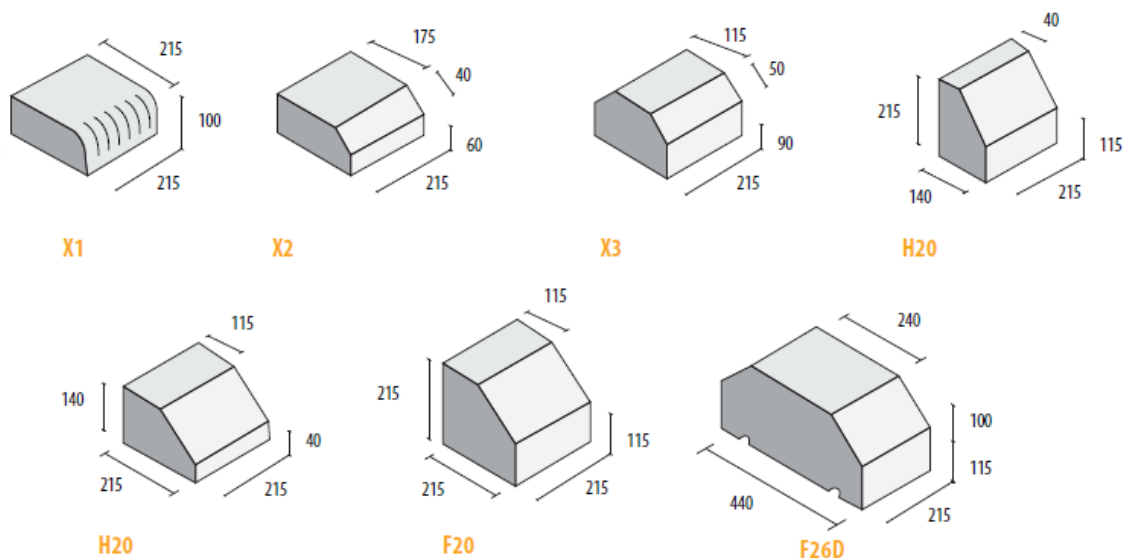

9. The performance of the product identified in points 1 and 2 is in conformity with the declared performance in point 8. This declaration of performance is issued under the sole responsibility of Roadstone Ltd.

Signed for and on behalf of the manufacturer by:

Alan Lowe, Senior Technical Manager, Roadstone Ltd.
(Name and Function)

Belgard, 28 Feb 2020
(Place and Date of Issue)

Alan Lowe

(Signature)

DECLARATION OF PERFORMANCE

Category 1 Aggregate Concrete Masonry Unit – Forticrete Specials

1. Unique identification code of the product type:

Code	Description	Strength (N/mm ²)	Length (mm)	Width (mm)	Height (mm)
X1E	Specials – External Corner	13	215	215	100
X2E	Specials – External Corner	13	215	215	100
F20C	Specials – External Corner	13	215	215	140
H20E	Specials – External Corner	13	215	215	215
H20C	Specials – External Corner	13	215	215	140
F20E	Specials – External Corner	13	215	215	215
F20S	Specials – External Corner	13	215	440	165

Refer to drawings below

2. Type, batch or serial number or any other element allowing identification of the construction product as required under Article 11(4) of the CPR:

Production details can be traced via dispatch docket.

3. Intended use or uses of the construction product, in accordance with the applicable harmonized technical specification, as foreseen by the manufacturer:

I.S. EN 771-3 2011 Aggregate Concrete Masonry Units (Dense and Lightweight) intended for use as common, facing or exposed masonry in load bearing or non-load bearing building and civil engineering applications in accordance with Irish building Regulations, TGD in particular parts A,B,C,D,E & L, Eurocode 6 and SR 325.

4. Name, registered trade name or registered trade mark and contact address of the manufacturer as required under Article 11(5):

Roadstone Ltd.
Fortunestown
Dublin 24

5. Not Applicable

6. System or systems of assessment and verification of constancy of performance of the construction product as set out in CPR, Annex V:

System 2+

7. Notified certification body:

NSAI (identification No. 050) performed the initial inspection of the manufacturing plant and of factory production control and the continuous surveillance, assessment and evaluation of factory production control, and issued the certificate of constancy of conformity of the factory production control.

Location	FPC Cert No.
Huntstown	0050-CPR-176

8. Declared Performance

Characteristic	Declared Performance	Technical Specification
Dimensional Tolerance	D1 (+3mm, -3mm)	I.S. EN 772-16
Configuration	Category 1 to EN 1996-1-1 Group 1 See diagram(s) below	EN 1996-1-1
Gross Density (Direct Airborne Sound Insulation)	>1900kg/m ³	I.S. EN 772-13
Net Density (Direct Airborne Sound Insulation)	>1900kg/m ³	I.S. EN 772-13
Compressive Strength (Mean)	As shown in Table above, in vertical orientation	I.S. EN 772-1 (7.3.5)
Thermal Conductivity	1.01 - 1.19 W/mK ($\lambda_{10,dry}$)	I.S. EN 1745 Annex A
Durability against freeze/thaw	F2 – Suitable for use in severe exposure	Tested in accordance with DD/CEN/TS 772:22 2006 Refer to TGD C, D & SR 325
Water Absorption	NPD	N/A
Moisture Movement	< 0.6 mm/m	I.S. EN 772-14
Water Vapour Permeability	5/15 μ	I.S. EN 1745 Annex A
Reaction To Fire	Class A1	Based on Commission Decision 200/605 EC amending 96/603 EC (Refer to I.S. EN 1996-1-2 National Annex Table NA. 3.1/3.2 & 3.3 for fire ratings of wall constructed with Class A1 Units)
Shear Bond Strength	0,15N/mm ² (Tabulated)	I.S. EN 998-2
Dangerous Substances	NPD	N/A

Normal Configuration (Vertical)

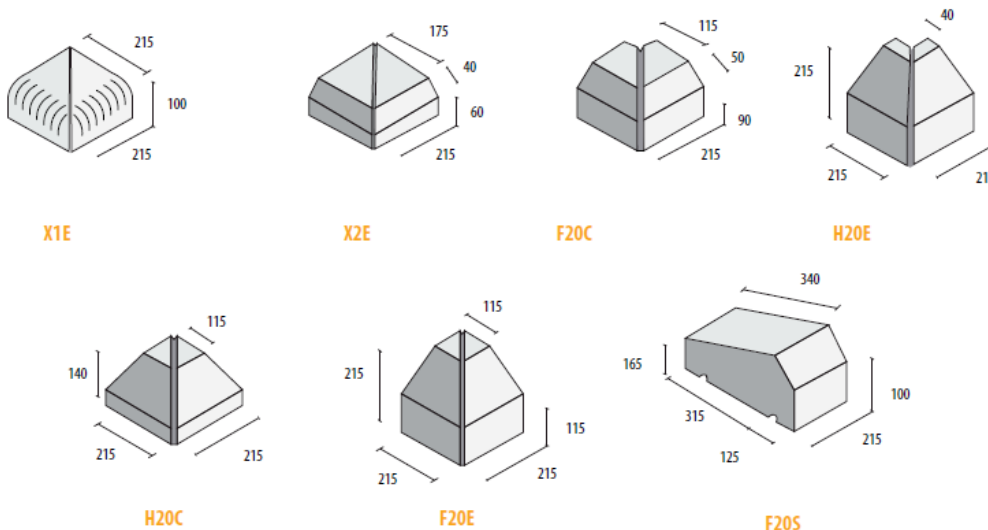

9. The performance of the product identified in points 1 and 2 is in conformity with the declared performance in point 8. This declaration of performance is issued under the sole responsibility of Roadstone Ltd.

Signed for and on behalf of the manufacturer by:

Alan Lowe, Senior Technical Manager, Roadstone Ltd.
(Name and Function)

Belgard, 28 Feb 2020
(Place and Date of Issue)

(Signature)

DECLARATION OF PERFORMANCE

Category 1 Aggregate Concrete Masonry Unit – Forticrete Specials

1. Unique identification code of the product type:

Code	Description	Strength (N/mm ²)	Length (mm)	Width (mm)	Height (mm)
X1F	Specials – Internal Corner	13	215	215	100
X2F	Specials – Internal Corner	13	215	215	100
X3F	Specials – Internal Corner	13	215	215	140
H20F	Specials – Internal Corner	13	140	140	215
XH20D	Specials – Internal Corner	13	215	215	140
F20F	Specials – Internal Corner	13	215	215	215
F20DS	Specials – Internal Corner	13	240	215	215

Refer to drawings below

2. Type, batch or serial number or any other element allowing identification of the construction product as required under Article 11(4) of the CPR:

Production details can be traced via dispatch docket.

3. Intended use or uses of the construction product, in accordance with the applicable harmonized technical specification, as foreseen by the manufacturer:

I.S. EN 771-3 2011 Aggregate Concrete Masonry Units (Dense and Lightweight) intended for use as common, facing or exposed masonry in load bearing or non-load bearing building and civil engineering applications in accordance with Irish building Regulations, TGD in particular parts A,B,C,D,E & L, Eurocode 6 and SR 325.

4. Name, registered trade name or registered trade mark and contact address of the manufacturer as required under Article 11(5):

Roadstone Ltd.
Fortunestown
Dublin 24

5. Not Applicable

6. System or systems of assessment and verification of constancy of performance of the construction product as set out in CPR, Annex V:

System 2+

7. Notified certification body:

NSAI (identification No. 050) performed the initial inspection of the manufacturing plant and of factory production control and the continuous surveillance, assessment and evaluation of factory production control, and issued the certificate of constancy of conformity of the factory production control.

Location	FPC Cert No.
Huntstown	0050-CPR-176

8. Declared Performance

Characteristic	Declared Performance	Technical Specification
Dimensional Tolerance	D1 (+3mm, -3mm)	I.S. EN 772-16
Configuration	Category 1 to EN 1996-1-1 Group 1 See diagram(s) below	EN 1996-1-1
Gross Density (Direct Airborne Sound Insulation)	>1900kg/m ³	I.S. EN 772-13
Net Density (Direct Airborne Sound Insulation)	>1900kg/m ³	I.S. EN 772-13
Compressive Strength (Mean)	As shown in Table above, in vertical orientation	I.S. EN 772-1 (7.3.5)
Thermal Conductivity	1.01 - 1.19 W/mK (λ10,dry)	I.S. EN 1745 Annex A
Durability against freeze/thaw	F2 – Suitable for use in severe exposure	Tested in accordance with DD/CEN/TS 772:22 2006 Refer to TGD C, D & SR 325
Water Absorption	NPD	N/A
Moisture Movement	< 0.6 mm/m	I.S. EN 772-14
Water Vapour Permeability	5/15μ	I.S. EN 1745 Annex A
Reaction To Fire	Class A1	Based on Commission Decision 200/605 EC amending 96/603 EC (Refer to I.S. EN 1996-1-2 National Annex Table NA. 3.1/3.2 & 3.3 for fire ratings of wall constructed with Class A1 Units)
Shear Bond Strength	0,15N/mm ² (Tabulated)	I.S. EN 998-2
Dangerous Substances	NPD	N/A

Normal Configuration (Vertical)

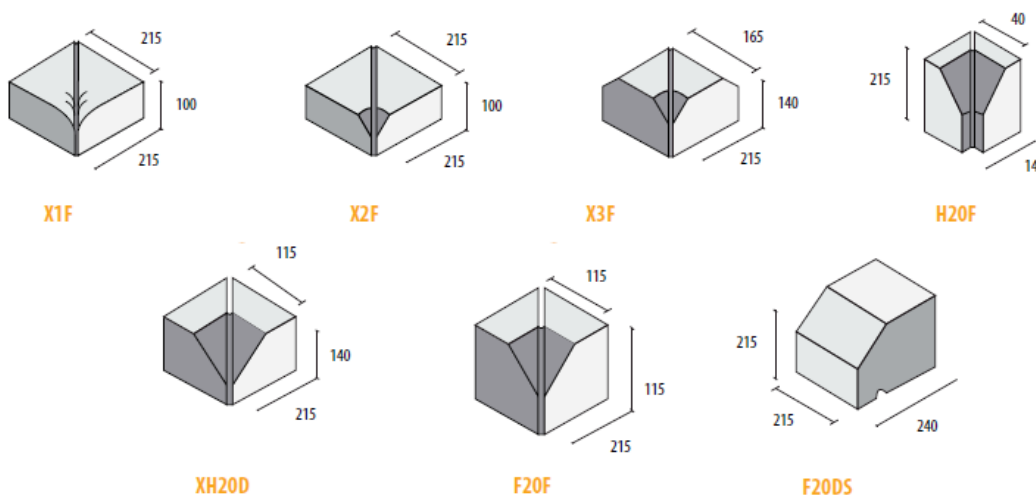

9. The performance of the product identified in points 1 and 2 is in conformity with the declared performance in point 8. This declaration of performance is issued under the sole responsibility of Roadstone Ltd.

Signed for and on behalf of the manufacturer by:

Alan Lowe, Senior Technical Manager, Roadstone Ltd.
(Name and Function)

Belgard, 28 Feb 2020
(Place and Date of Issue)

Alan Lowe

(Signature)



13

DECLARATION OF PERFORMANCE

Category 1 Aggregate Concrete Masonry Unit – Forticrete Specials

1. Unique identification code of the product type:

Code	Description	Strength (N/mm ²)	Length (mm)	Width (mm)	Height (mm)
X1B	Forticrete Specials	13	65	215	100
X2B	Forticrete Specials	13	65	215	100
X3B	Forticrete Specials	13	65	165	140
H20B	Forticrete Specials	13	65	140	215
F20B	Forticrete Specials	13	65	215	215
X45	Forticrete Specials - 135° extension at one end	13	147/215E ^a	100	215
			35/77E ^a		
R20D	Forticrete Specials	13	190	390	190

Refer to drawings below

2. Type, batch or serial number or any other element allowing identification of the construction product as required under Article 11(4) of the CPR:

Production details can be traced via dispatch docket.

3. Intended use or uses of the construction product, in accordance with the applicable harmonized technical specification, as foreseen by the manufacturer:

I.S. EN 771-3 2011 Aggregate Concrete Masonry Units (Dense and Lightweight) intended for use as common, facing or exposed masonry in load bearing or non-load bearing building and civil engineering applications in accordance with Irish building Regulations, TGD in particular parts A,B,C,D,E & L, Eurocode 6 and SR 325.

4. Name, registered trade name or registered trade mark and contact address of the manufacturer as required under Article 11(5):

Roadstone Ltd.
Fortunestown
Dublin 24

5. Not Applicable

6. System or systems of assessment and verification of constancy of performance of the construction product as set out in CPR, Annex V:

System 2+

7. Notified certification body:

NSAI (identification No. 050) performed the initial inspection of the manufacturing plant and of factory production control and the continuous surveillance, assessment and evaluation of factory production control, and issued the certificate of constancy of conformity of the factory production control.

Location	FPC Cert No.
Huntstown	0050-CPR-176

8. Declared Performance

Characteristic	Declared Performance	Technical Specification
Dimensional Tolerance	D1 (+3mm, -3mm)	I.S. EN 772-16
Configuration	Category 1 to EN 1996-1-1 Group 1 See diagram(s) below	EN 1996-1-1
Gross Density (Direct Airborne Sound Insulation)	>1900kg/m ³	I.S. EN 772-13
Net Density (Direct Airborne Sound Insulation)	>1900kg/m ³	I.S. EN 772-13
Compressive Strength (Mean)	As shown in Table above, in vertical orientation	I.S. EN 772-1 (7.3.5)
Thermal Conductivity	1.01 - 1.19 W/mK (λ10,dry)	I.S. EN 1745 Annex A
Durability against freeze/thaw	F2 – Suitable for use in severe exposure	Tested in accordance with DD/CEN/TS 772:22 2006 Refer to TGD C, D & SR 325
Water Absorption	NPD	N/A
Moisture Movement	< 0.6 mm/m	I.S. EN 772-14
Water Vapour Permeability	5/15μ	I.S. EN 1745 Annex A
Reaction To Fire	Class A1	Based on Commission Decision 200/605 EC amending 96/603 EC (Refer to I.S. EN 1996-1-2 National Annex Table NA. 3.1/3.2 & 3.3 for fire ratings of wall constructed with Class A1 Units)
Shear Bond Strength	0,15N/mm ² (Tabulated)	I.S. EN 998-2
Dangerous Substances	NPD	N/A

Normal Configuration (Vertical)

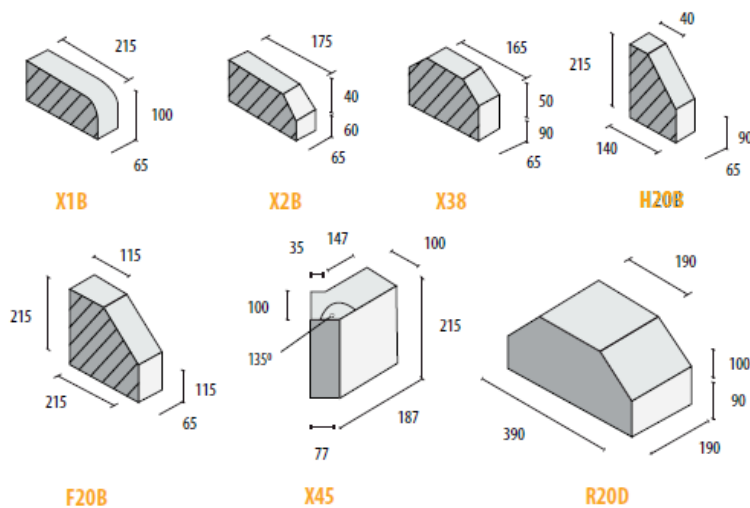

9. The performance of the product identified in points 1 and 2 is in conformity with the declared performance in point 8. This declaration of performance is issued under the sole responsibility of Roadstone Ltd.

Signed for and on behalf of the manufacturer by:

Alan Lowe, Senior Technical Manager, Roadstone Ltd.
(Name and Function)

Belgard, 28 Feb 2020
(Place and Date of Issue)

Alan Lowe

(Signature)