

Up-Flo™ Filter

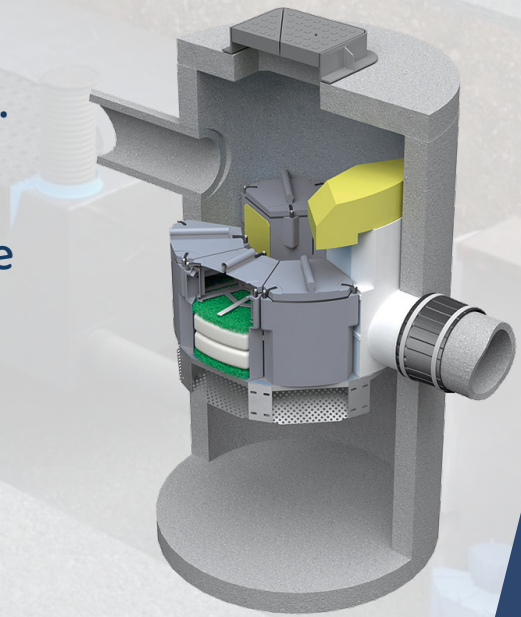

Fluidised Bed Up-Flow Filtration System.
The Up-Flo™ Filter is an innovative surface water filtration technology that delivers a high-performance multi-stage treatment train within a single device.

The Up-Flo™ Filter combines sedimentation and screening with fluidised bed filtration technology to deliver high levels of performance.



Benefits

Modular filtration components allow you to adapt your design to meet catchment needs.

The Up-Flo™ Filter combines pre-treatment, screening and filtration, delivering highly efficient multi-stage treatment in one device.

Higher loading rates result in a small treatment footprint, which saves construction time and money and makes for an easier installation.

No moving parts means there is less opportunity for treatment disruption, while the design is suited to long-term maintenance. Longer media life means longer service intervals, and media bags are easily removed and replaced.

Targeted Removals

Very fine particles

Gross pollutants (litter / leaf debris)

Liquid and sediment bound hydrocarbons

Sediment bound heavy metals and sediment bound nutrients

Application Information

For high-density urban environments where high pollutant loadings need to be managed in limited space. For both new-build or retrofit situations for residential, commercial or industrial developments, highways and car parks.